

SAMODOMYKACZ 50 kg - nr 1692

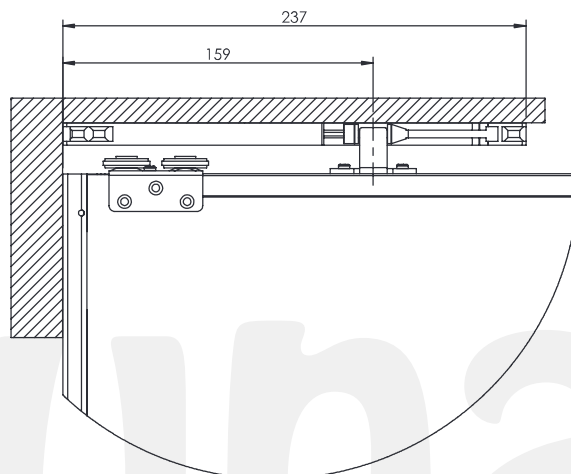

SAMODOMYKACZ CENTRO 50 kg - nr 1691

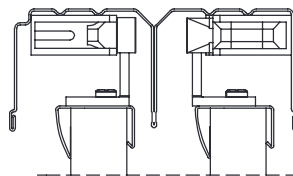
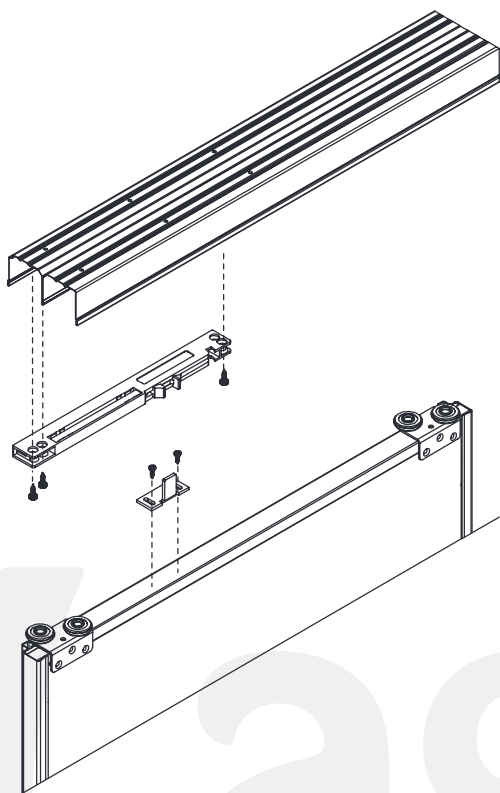